



New **Brandon** Range Cooker

STANLEY

TURNING YOUR HOUSE INTO A HOME



a fusion of contemporary styling and authentic design

...our **NEW** Brandon Range Cooker

With its elegant detailing and carefully crafted finish, the stunning new Brandon strikes the perfect note between past and present in your home.

Underneath the new exterior with its sleek lines and gentle curves, this model delivers more functionality than ever before. Digital display and intuitive electronic controls ensure that you can easily optimise heating, hot water and cooking with greater precision. The new Brandon has also been re-engineered to meet the needs of modern living.

A signature piece in every home, the Brandon is about so much more than heating and cooking, it is a link to be cherished between time-honoured tradition and contemporary living.

introducing...

More control, more freedom

The new Brandon has been carefully engineered to meet the needs of busy family homes in the 21st century.

- Multi-functional and easy to use so that you can control cooking, heating and hot water all at the same time.
- A beautiful and enduring style statement at the heart of your kitchen.
- Durability and reliability that will stand the test of time.
- Versatile engineering that is compatible with meeting modern home comforts such as underfloor heating.

The new Brandon exceeds all expectations in terms of performance, liberating you to enjoy your home with unparalleled levels of comfort and cooking pleasure.



A Tradition for Today

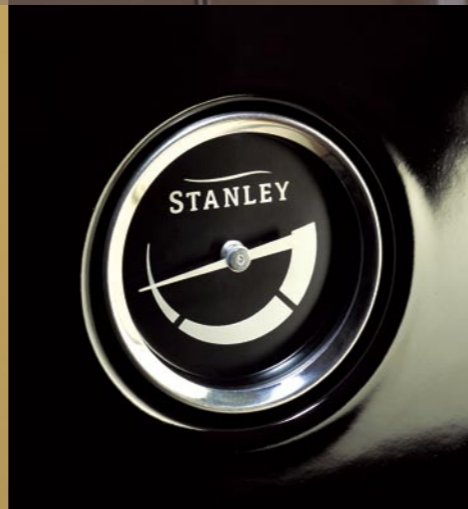

Excellence as standard

PERFORMANCE

- Suitable for underfloor heating and zoning
- Ovens have rapid heat-up time
- Available In Oil or Natural Gas versions
- Brandon 60, 80, and 100 offer heating (between 12 – 20 radiators), hot water and cooking functionality
- Brandon 10 offers cooking plus sufficient hot water for a typical household
- Brandon Cooker offers dedicated cooking functionality only.

STYLE

- Twin Chrome Hotplate Covers
- New Simmer Plate Cover
- Chrome Towel Rail
- Stylish Stanley Badging and Temperature Gauge.

CONTROL

- Automatic seven-day programmer
- Digital Display and Electronic Controls
- 3 channel timer for separate control of hot water, central heating and oven preheat to 150°C
- Dedicated on/off time for cooking.



Slow-cooking the modern way

The gentle heat that radiates from the cast iron interior of the Brandon brings out the full flavour of food, infusing casseroles and roasts with aromatic flavours and making meat more succulent and mouthwateringly-tender. The Brandon is particularly suited to baking, puffing up cakes and breads in the upper part of the oven while pizzas crisp on the oven floor. The hotplate with its stylish chrome lids offers a range of cooking temperatures from a gentle rolling simmer to a rapid boil - perfect for steaming, boiling or stir-frying.

New digital controls mean that you can precisely manage the temperature within the oven chamber. Its large capacity main oven makes cooking for large groups a breeze while the lower oven is perfect for warming or slow-cooking. Both ovens are vented into the external flue, meaning that cooking odours are extracted outside.

By using the hotplate, the warming plate, the main oven and the simmering oven in combination you have every level of heat you need to indulge your passion for good food.

The Art of Delicious Food

Range cooking for the digital age

- Countdown timers, alarm functions
- Electronic oven temperature controls
- Radiant heat ensures food retains moisture
- Large capacity oven 28 litres - can hold a 28lb turkey
- Oven temperature can be monitored through the digital display.
- Ovens vented outside, reducing odour and condensation
- The simmering oven operates at half the temperature of the main oven.



Main Oven

The large capacity main oven, 390mm X 220mm, comfortably accommodating a 28lb turkey.

Hotplate and Simmering Plate

The hotplate's large capacity and range of temperatures means you can boil, simmer and steam simultaneously.

Browning and Baking

The main oven is perfect for browning and baking.

Simmering Oven

The simmering oven is perfect for slow baking or warming dishes.



Tailored to your lifestyle

Cosy kitchens on cold mornings, gentle heat underfoot, hot water on tap when you need it, the Brandon brings a luxurious warmth to your home that is tailored to your lifestyle.

Using its 7-day programming feature with digital control, you can create a weekly heating plan for your home that changes on a daily basis to suit the busy lives of your family. With the powerful capability of heating up to 20 standard radiators, the Brandon also integrates seamlessly with modern underfloor heating systems.

Water is heated rapidly and its advanced twin burner technology ensures that you can control heating, hot water and cooking functions separately to one another.

Designed to run on a choice of fuels, the new Brandon is a true design classic for the next generation.

your home with Stanley

the comfort of total reliability

- Can be flued without a chimney using a fan flue kit or twin walled flue pipe
- Fully compatible with underfloor heating
- Separate control of hot water, central heating and oven preheat to 150°C
- Seven day, three channel digital timer
- Rapid water heating - 45 minutes to heat a 60 gallon tank of water to 45 degrees
- 8,000 BTU's of radiant heat at 200 degrees
- Integrated fault finding diagnostics
- Programmable hot water



Independent control of hot water, cooking and heating



Fully compatible with underfloor heating



Digital controls mean heating and hot water when you need it

Specifications

Model Specifications

Features	Brandon 100	Brandon 80	Brandon 60	Brandon 10	Brandon Cooker
Function					
Cooking	•	•	•	•	•
Domestic hot water (DHW)	•	•	•	•	•
Central heating	•	•	•	•	•
Ovens					
Cast iron main oven	•	•	•	•	•
Cast iron lower cooking oven	•	•	•	•	•
Controls					
Digital control panel	•	•	•		
Analog programmer				•	
Digital programmer					•
Fuel options					
Oil	•	•	•	•	•
Natural gas	•	•	•	•	•
Flue System					
Conventional	•	•	•	•	•
Twin walled	•	•	•	•	•
Fan assisted	•	•	•	•	•
Central heating hot water system					
Fully pumped open system	•	•	•	•	
Fully pumped sealed system	•	•	•	•	
Hot water storage					
Suitable for most cylinder sizes	•	•	•	•	•
Electricity supply required	•	•	•	•	•
Boiler output	100,000 Btu/h 29.3kW	80,000 Btu/h 23.4kW	60,000 Btu/h 17.6kW	10,000 Btu/h 2.9kW	Cooker only N/A
Average No. of radiators	20	16	12	N/A	N/A
Weight	385Kg (850 lbs)	380Kg (838 lbs)	380Kg (838 lbs)	355Kg (782lbs)	355Kg (782lbs)

Dimensions

Front view	A	B	C	D
Metric (mm)	920	922	1480	560
Imperial (inches)	36 ¹ / ₄	36 ¹ / ₄	58 ¹ / ₄	22

Side view	E	F	G	H	I	J	K
Metric (mm)	640	45	250	1047	150	540	N/A
Imperial (inches)	25 ¹ / ₅	1 ³ / ₄	9 ⁷ / ₈	41 ¹ / ₄	6	21 ¹ / ₄	1*

*BSP female

Hotplate & oven dimensions

Feature	Metric (mm)			Imperial (inches)		
	width	height	depth	width	height	depth
Hotplate	500	-	323	25 ⁷ / ₈	-	12 ¹ / ₄
Roasting oven	390	310	406	15 ¹ / ₄	12 ¹ / ₄	16
Simmering oven	390	220	406	15 ¹ / ₄	8 ³ / ₄	16

Hotplate zoning

Different parts of the hot plate operate at different temperatures, giving you access to a range of cooking heats at any one time.

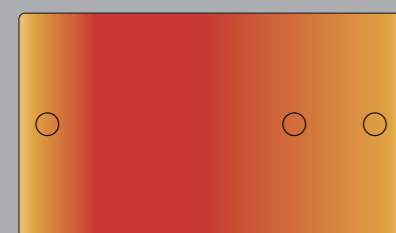

Hotplate temperature zones

Brandon options & accessories

The colours of Brandon

The Stanley Brandon is available in a choice of 6 classic enamel colours*.



Cream Black Blue Forest Green Claret Mink

New Brandon hood

A Stanley Brandon extractor hood combines high performance (750m³/h) with supremely quiet (49db) operation. The hood has a choice of 3 speeds and has two integrated halogen lights. The hood has a stainless steel surround, with a coloured front panel to match the colour of your Brandon. The hood allows for vertical fluing through the hood.

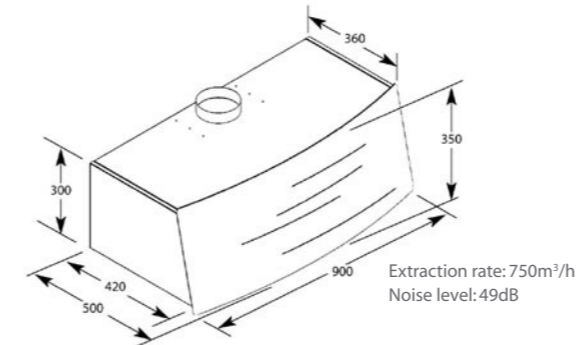

Stanley plate rack & splashback

A cast iron plate rack and splashback provide a stylish and practical way to keep plates and serving dishes warm. The plate rack and splashback are available in a range of colours to match your Brandon range cooker.



Stanley Cookware

For the best cooking performance on your Brandon, it is imperative that a heavy based machine ground pot or pan is used. This 5 piece Stanley range of cast iron cookware has been specifically designed to optimise range cooking performance – bringing out the true flavour of your food.



Stanley Cookbook

Cooks love their Stanley! Handcrafted from cast iron, it is perfect for baking and wonderful for slow-cooking casseroles and roasts. To help you get to know your Stanley, we have produced this cookbook containing many recipes that are ideally suited to the exceptional qualities of the Stanley Range Cookers.



* Print colours may not necessarily reflect the actual colour of the cooker/hood. Drop into your local Stanley stockists to view precise colours

Technical information

How your Brandon works

The Brandon cooker uses an separate burners for central heating and cooking, which allow you to programme your central heating, hot water and cooking requirements independently. For fully automated operation of central heating and domestic hot water there is a requirement for central heating controls such as motorised valves that will operate in conjunction with the cooker.

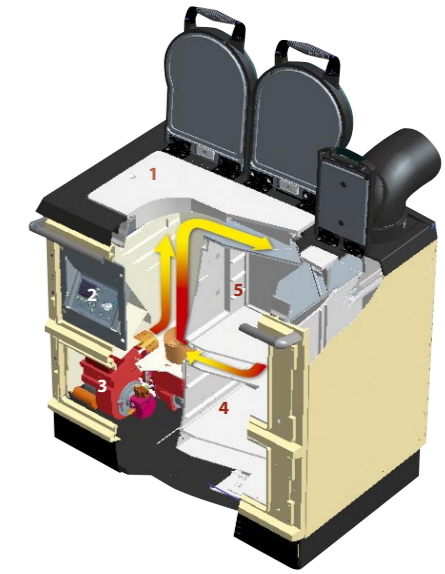

Inside your Brandon
1. Hotplate
2. Digital control panel
3. Burner unit
4. Simmering oven
5. Main oven

Flueing options

When installing your Stanley Range Cooker, we recommend using Stanley parts and flue systems only. Stanley Flexi Flue and Twin-Walled Flue systems are available for use with a suitable chimney. For those homes without a chimney a Fan Flue or Twin-Walled Flue system is available.

Choosing a fan flue

A fan flue is the ideal solution for homes without a chimney as it allows you to flue through any suitable external wall. There are three models of fan flue to choose from, depending on your chosen model of range cooker.

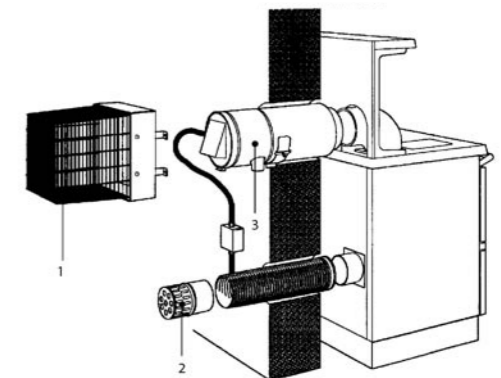

Twin powered fan
1. Safety cage
2. Air intake assembly
3. Fan flue

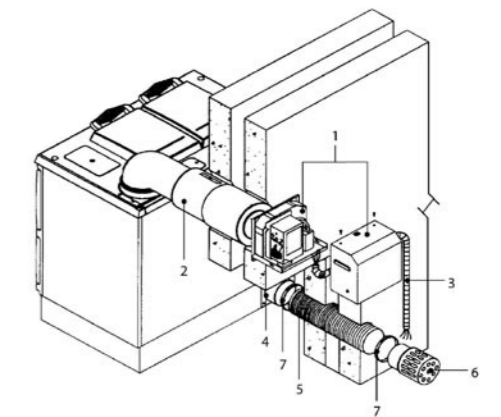

FT10/FT20-G fan flue
1. FT20-G fan flue terminal complete with cover
2. Twin wall adjustable section of flue
3. Connection cable
4. Primary air inlet spigot
5. Air inlet duct
6. Air inlet terminal
7. Jubilee clips

Models	Fuel	Fan flue type
Brandon 100/80/60	Oil	Twin powered
Brandon 10/Brandon Cooker	Oil	FT10
Brandon 100/80	Gas	FT20-G
Brandon 60/10/Cooker	Gas	FT10

Installation & Commissioning

For generations, Stanley Range Cookers have been renowned for their durability, superb efficiency and powerful performance. When it comes to ensuring your new range cookers safe and efficient operation we recommend using a Stanley approved installer. For total piece of mind, we recommend having a site survey carried out before purchase. Once your range cooker has been installed, it must be commissioned by a Stanley engineer in order to validate your warranty.

Servicing

In order to ensure the safe operation of your range cooker, we recommend that it is serviced once a year. All Gas appliances should be checked regularly by a service engineer.

Warranty

Waterford Stanley will replace free of charge, any working part that fails (under normal operating conditions) within 12 months of purchase. To validate your warranty, your Brandon Range Cooker must be commissioned by a Stanley Engineer.

Spare Parts

Your local Stanley dealer will be pleased to supply spare parts and to provide any other information you require.

For any technical inquiries please call;
Republic of Ireland: 051 302 333
UK: 0870 751 2521
Northern Ireland: 028 8772 2195



STANLEY



Waterford Stanley Ltd.,
Billberry, Waterford, Ireland

Republic of Ireland -
General Number: 051 302 300
Sales Dept: 051 302 302
Lo-call: 1850 302 502
Fax: 051 302 315

UK Sales Dept: 01978 290 865
UK Order Fax Line: 01978 290 885

Northern Ireland Sales Dept: 028 8772 2195

www.waterfordstanley.com